

MATHEMATICS

Chapter 10: Practical Geometry



Practical Geometry

1. If two lines are cut by a transversal such that their alternate angles are equal, then the lines are parallel. This concept is used to construct a line parallel to a given line l passing through a point not on the line l .
2. A triangle is said to be
 - a. an equilateral triangle, if all of its sides are equal.
 - b. an isosceles triangle, if any two of its sides are equal.
 - c. a scalene triangle, if all of its sides are of different length.
3. A triangle is said to be
 - a. an acute angled triangle, if each one of its angles measure less than 90° .
 - b. a right angled triangle, if any one of its angles measure 90° .
 - c. an obtuse angled triangle, if any one of its angles measure more than 90° .
4. A triangle can be constructed if the lengths of its three sides are given.
5. A triangle can be constructed if the length of its two sides and the included angle are given.
6. A triangle can be constructed if its two angles and the length of the included side are given.
7. A right angled triangle can be constructed if we are given the hypotenuse and the length of one of its legs.

Lines That Don't Meet

Method of construction of a line parallel to a given line, using only a sheet of paper

- Take a piece of paper.
- Fold it in half and unfold the line l . Mark a point A on paper outside l .
- Fold the paper perpendicular to the line such that this perpendicular passes through A . Name the perpendicular AN .
- Make a fold perpendicular to AN through point A . Name the new perpendicular line as m .
- Now, $l \parallel m$.

Parallel Lines

Have you ever observed the railway tracks or the opposite edges of a door? One of the interesting facts about these is that they are examples of parallel lines. Now the question arises what exactly are parallel lines? The lines which do not have a common meeting point in the same plane, however far they are extended are known as parallel lines. The following figure represents parallel lines:

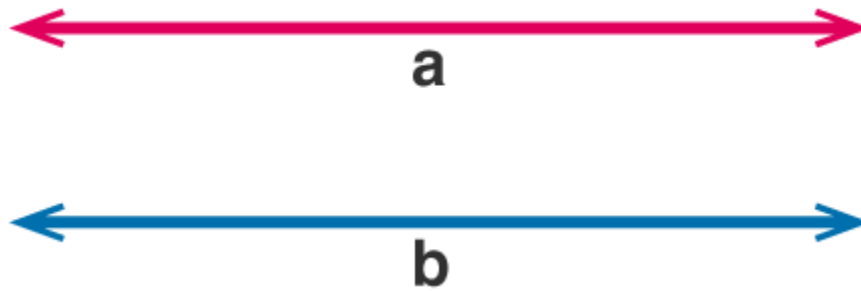

Two lines are said to be parallel in a plane if they do not intersect if extended till infinite in both the directions. The distance between two lines is similar throughout the whole length. The symbol to denote the parallel lines is $||$. Suppose the two lines 'a' and 'b' are parallel to each other, we can express their parallel nature using a symbol by $a || b$ and read as 'a is parallel to b'.

Steps of construction of a line parallel to a given line

- Take a line l and a point A outside l .
- Take any point B on l and join it to A .SSS

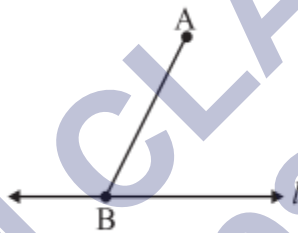

- With B as the centre and a convenient radius, cut an arc on l at C and BA at D .

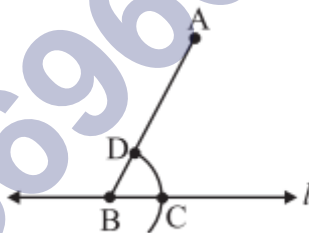

- With A as the centre and same radius as in Step 3, cut an arc EF to cut AB at G .

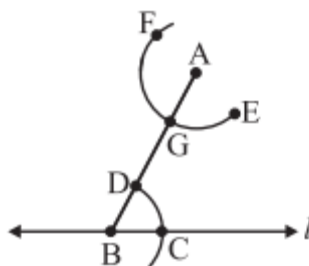

- Measure the arc length CD by placing pointed tip of the compass at C and pencil tip

(2)

opening at D.

- With this opening, keep G as centre and draw an arc to cut arc EF at H

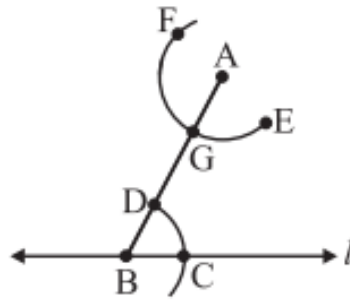

- Join AH to draw a line m

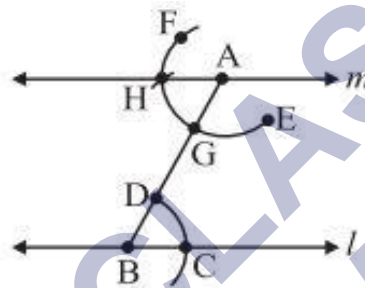

Slope

In Mathematics, a slope of a line is the change in y coordinate with respect to the change in x coordinate.

The net change in y-coordinate is represented by Δy and the net change in x-coordinate is represented by Δx .

Hence, the change in y-coordinate with respect to the change in x-coordinate is given by,

$$m = \text{change in } y / \text{change in } x = \Delta y / \Delta x$$

Where "m" is the slope of a line.

The slope of the line can also be represented by

$$\tan \theta = \Delta y / \Delta x$$

So, $\tan \theta$ to be the slope of a line.

Generally, the slope of a line gives the measure of its steepness and direction. The slope of a straight line between two points says (x_1, y_1) and (x_2, y_2) can be easily determined by finding the difference between the coordinates of the points. The slope is usually represented by the letter 'm'.

Slope Formula

If P (x_1, y_1) and Q (x_2, y_2) are the two points on a straight line, then the slope formula is given by:

Slope, $m = \text{Change in } y\text{-coordinates} / \text{Change in } x\text{-coordinates}$

$$m = (y_2 - y_1) / (x_2 - x_1)$$

Therefore, based on the above formula, we can easily calculate the slope of a line between two points.

In other term, the slope of a line between two points is also said to be the rise of the line from one point to another (along y-axis) over the run (along x-axis). Therefore,

$$\text{Slope, } m = \text{Rise/Run}$$

Slope of a Line Equation

The equation for the slope of a line and the points also called point slope form of equation of a straight line is given by:

$$y - y_1 = m (x - x_1)$$

Whereas the slope-intercept form the equation of the line is given by:

$$y = mx + b$$

Where b is the y-intercept.

How to Find Slope of a Line on a Graph?

In the given figure, if the angle of inclination of the given line with the x-axis is θ then, the slope of the line is given by $\tan \theta$. Hence, there is a relation between the lines and angles. In this article, you will learn various formulas related to the angles and lines.

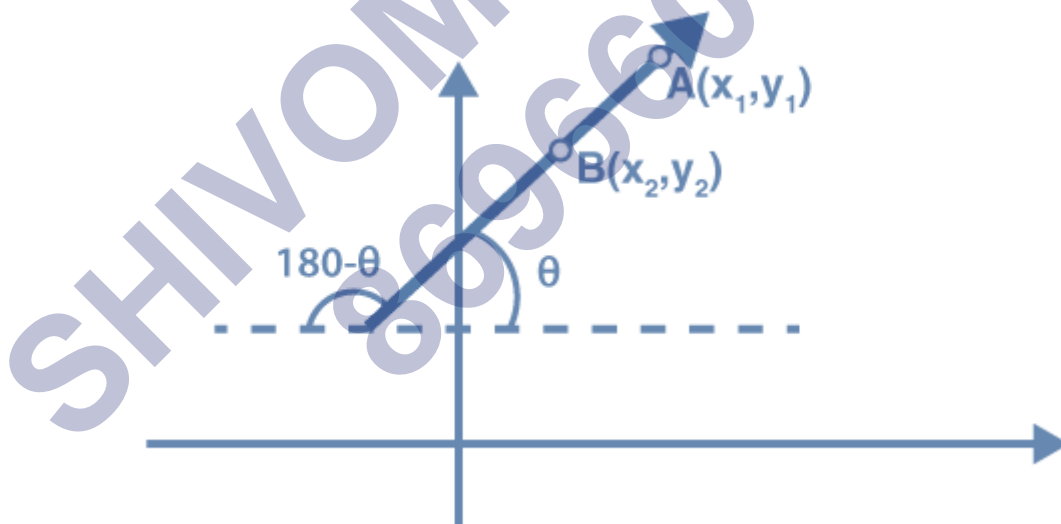

The slope of a line is given as $m = \tan \theta$. If two points A (x_1, y_1) and B (x_2, y_2) lie on the line with ($x_1 \neq x_2$) then the slope of the line AB is given as:

$$m = \tan \theta = \frac{y_2 - y_1}{x_2 - x_1}$$

Where θ is the angle which the line AB makes with the positive direction of the x-axis. θ lies between 0° and 180° .

It must be noted that $\theta = 90^\circ$ is only possible when the line is parallel to y-axis i.e. at $x_1 = x_2$ at this particular angle the slope of the line is undefined.

Conditions for perpendicularity, parallelism, and collinearity of straight lines are given below:

Slope for Parallel Lines

Consider two parallel lines given by l_1 and l_2 with inclinations α and β respectively. For two lines to be parallel their inclination must also be equal i.e. $\alpha = \beta$. This results in the fact that $\tan \alpha = \tan \beta$. Hence, the condition for two lines with inclinations α, β to be parallel is $\tan \alpha = \tan \beta$.

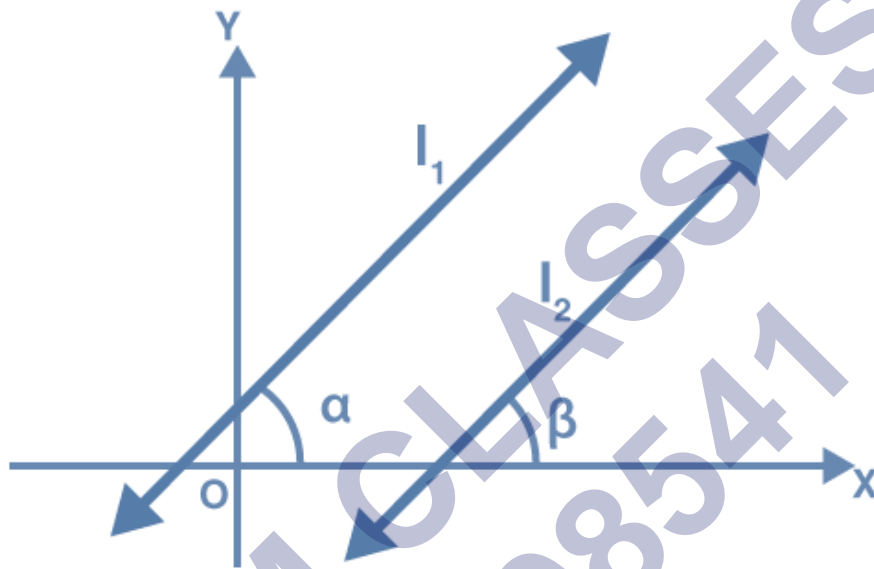

Therefore, if the slopes of two lines on the Cartesian plane are equal, then the lines are parallel to each other.

Thus, if two lines are parallel then, $m_1 = m_2$.

Generalizing this for n lines, they are parallel only when the slopes of all the lines are equal.

If the equation of the two lines are given as $ax + by + c = 0$ and $a'x + b'y + c' = 0$, then they are parallel when $ab' = a'b$.

Let's Build Triangles

Classification of triangles based on sides and angles

Triangles can be classified based on their:

Sides:

Equilateral triangle: All three sides are equal in measure.

Isosceles triangle: Two sides have equal measure.

Scalene triangle: All three sides have different measures.

Angles:

Acute triangle: All angles measure less than 90° .

Obtuse triangle: One angle is greater than 90° .

Right triangle: One angle is 90° .

Important properties of triangles

- The exterior angle is equal to the sum of interior opposite angles.
- The sum of all interior angles is 180°
- Sum of the lengths of any two sides is greater than the length of the third side.
- Pythagoras theorem: In any right-angled triangle, the square of the hypotenuse is equal to the sum of the squares of the other two sides.

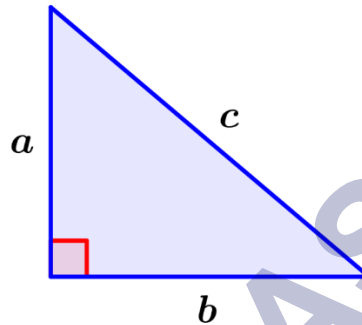

$$c^2 = a^2 + b^2$$

Triangles can be constructed if any of the following measurements are given

- Three sides.
- Two sides and an angle between them.
- Two angles and a side between them.
- The hypotenuse and a leg in case of a right-angled triangle.

Construction of triangles given a criterion are listed below:

Construction of a triangle with SSS criterion.

Construct a triangle ABC, given that $AB = 4.5$ cm, $BC = 5$ cm and $AC = 6$ cm.

Steps:

- Make a rough sketch for your reference
- Draw a line segment $BC = 5$ cm

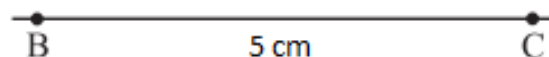

- With B as centre, draw an arc of radius 4.5 cm

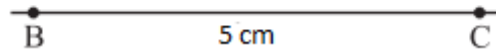

- With C as centre, draw an arc of radius 6 cm and cut the previous arc

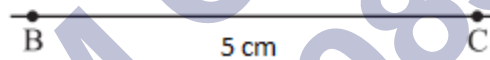

- Mark the point of intersection of arcs as A. Join AB and AC. ΔABC is now ready

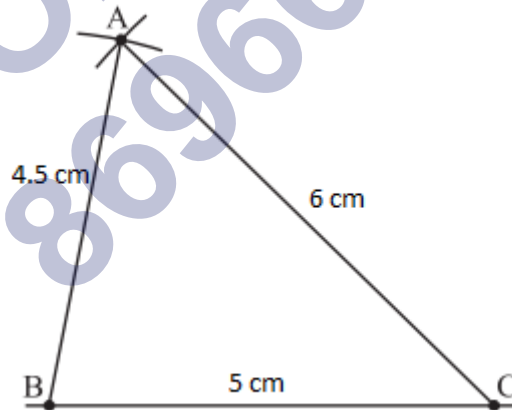

Note: SSS congruency rule: If three sides of one triangle are equal to the corresponding three sides of another triangle, then the two triangles are congruent

Construction of a triangle with SAS criterion

Construct ΔPQR with $QR = 7.5$ cm, $PQ = 5$ cm and $\angle Q = 60^\circ$.

Steps:

- Make a rough sketch for your reference
- Draw a line segment $QR = 7.5$ cm

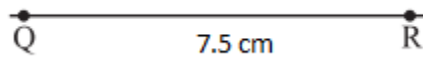

- At Q, draw QX making 60° with QR

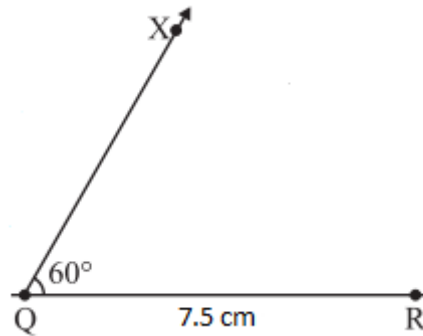

- With Q as centre, draw an arc of radius 5 cm. It cuts QX at P.

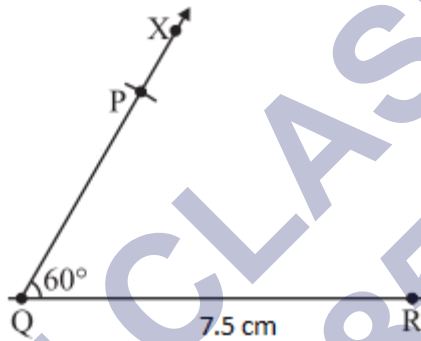

- Join AB. ΔPQR is now ready

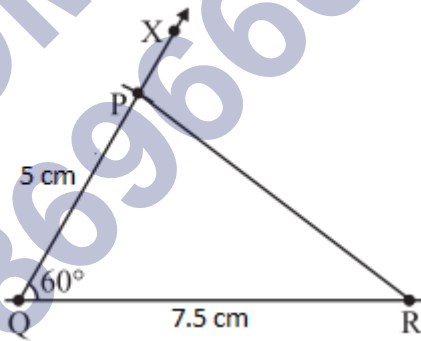

Construction of a triangle with ASA criterion

Construct ΔXYZ with $\angle X = 30^\circ$, $\angle Y = 100^\circ$ and $XY = 5.8$ cm.

Steps:

- Make a rough sketch for your reference
- Draw $XY = 5.8$ cm

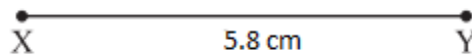

- At X, draw a ray XP making an angle of 30° with AB.

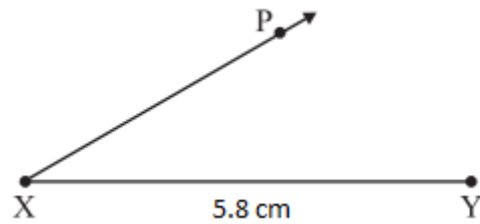

- At Y, draw a ray YQ making an angle of 100° with XY.

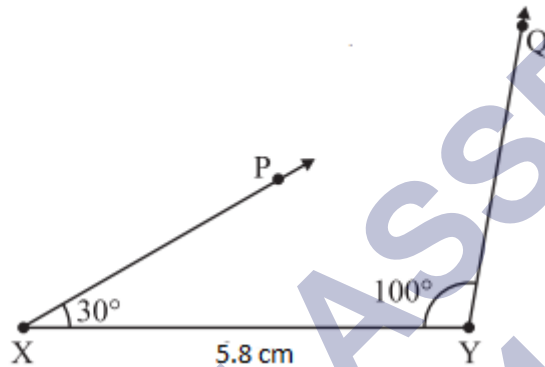

- The point of intersection of the two rays is Z.
- ΔXYZ is now completed

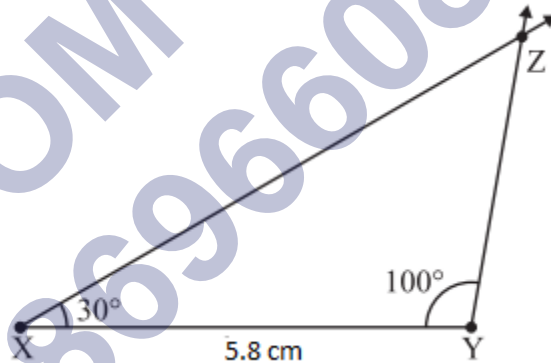

Construction of a triangle with RHS criterion

Construct ΔLMN , where $\angle M = 90^\circ$, $MN = 8\text{ cm}$ and $LN = 10\text{ cm}$.

Steps:

- Make a rough sketch for your reference
- Draw $MN = 8\text{ cm}$

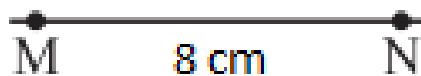

- At M, draw $MX \perp MN$.

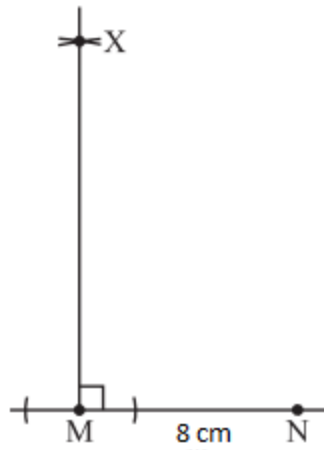

- With N as centre, draw an arc of radius 10 cm to cut MX at L

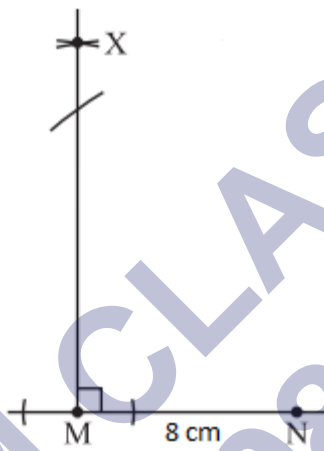

- Join LN.
- $\triangle LMN$ is now completed

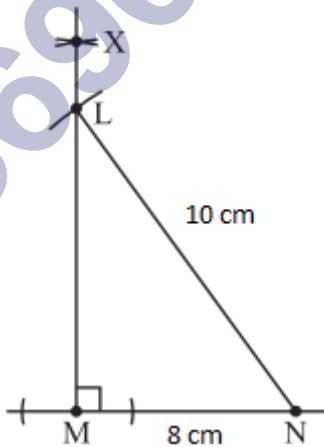

Basics of Practical Geometry

Introduction to Constructions of basic figures

Basic constructions:

- To draw a line segment of given length
- a line perpendicular to a given line segment

- an angle
- an angle bisector
- a circle

In geometry, you have already studied basic constructions.

To recap, some of them are:

- Drawing a line segment of given length
- Drawing a line perpendicular to a given line segment.
- Angles
- Angle bisectors
- Circles
- Tools used for simple constructions are ruler, protractor and a compass.

SHIVOM CLASSES
8696608541

Class : 7th mathematics
Chapter-10 : Practical Geometry

Practical Geometry

Meaning
It is a geometry done practically i.e. using compass, protactor, etc. It usually consists of constructions of polygon figures such as triangle etc.

What is practical geometry?

(Step-1)
Take a line 'l' and a point 'A' outside 'l'.



(Step-2)
Take any point B on l and join B to A.

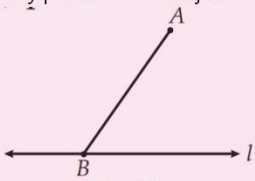

(Step-3)
With B as a centre and a convenient radius, draw an arc cutting l at C and AB at D.

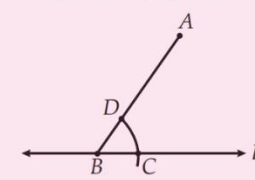

(Step-4)
With B as a centre and a convenient radius, draw an arc cutting l at C and AB at D.

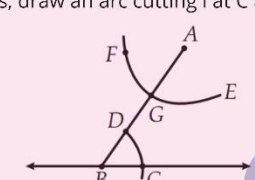

(Step-5)
Place the compass tip at C and pencil tip at D.

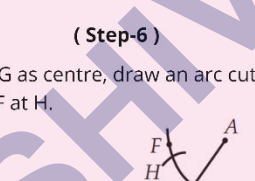

(Step-6)
With G as centre, draw an arc cutting the arc EF at H.

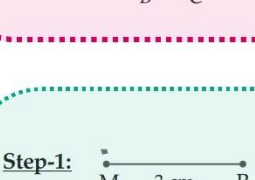

Construction of a line parallel to given line through a point not on the line

Construction of Triangles

With three sides (S.S.S. Criterion)

With two sides & angle between them (S.A.S. Criterion)

With the two angles & the sides between them (A.S.A. Criterion)

With a hypotenuse & a leg in right angled Triangle (R.H.S. Criterion)

Rough Sketch :

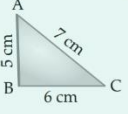

Step-1: 

Step-2: Draw an arc of 5 cm 

Step-3: Draw an arc of 7 cm which cuts previous arc 

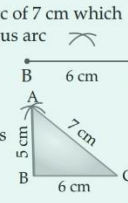
Step-4: Join the lines 

Rough Sketch :

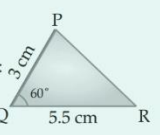

Step-1: 

Step-2: 

Step-3: 

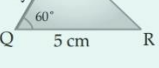
Step-4: 

Rough Sketch :

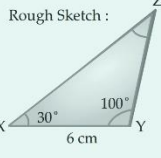

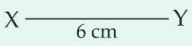
Step-1: 

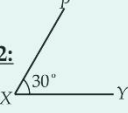
Step-2: 

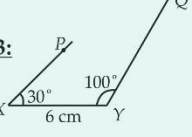
Step-3: 

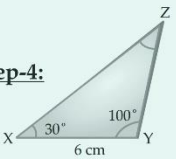
Step-4: 

Step-1: 

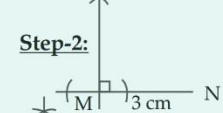
Step-2: 

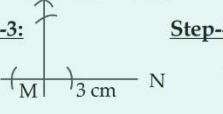
Step-3: 

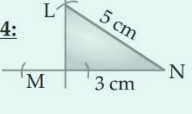
Step-4: 

Important Questions

Multiple Choice Questions-

Question 1. In ΔRST , $R = 5$ cm, and $\angle SRT = 45^\circ$ and $\angle RST = 45^\circ$. Which criterion can be used to construct ΔRST ?

- (a) A.S.A. criterion
- (b) S.A.S. criterion
- (c) S.S.S. criterion
- (d) R.H.S. criterion

Question 2. Identify the criterion of construction of the equilateral triangle LMN given $LM = 6$ cm.

- (a) S.A.S. criterion
- (b) R.H.S. criterion
- (c) A.S.A. criterion
- (d) S.S.S. criterion

Question 3. The idea of equal alternate angles is used to construct which of the following?

- (a) A line parallel to a given line
- (b) A triangle
- (c) A square
- (d) Two triangles

Question 4. A Given $AB = 3$ cm, $AC = 5$ cm, and $\angle B = 30^\circ$, ΔABC cannot be uniquely constructed, with AC as base, why?

- (a) Two sides and included angle are given.
- (b) The other two angles are not given.
- (c) The vertex B cannot be uniquely located.
- (d) The vertex A coincides with the vertex C.

Question 5. A line p and a point X not on it are given. Which of the following is used to draw a line parallel to p through X?

- (a) Equal corresponding angles.
- (b) Congruent triangles.
- (c) Angle sum property of triangles.
- (d) Pythagoras' theorem.

Question 6. ΔPQR is such that $\angle P = \angle Q = \angle R = 60^\circ$ which of the following is true?

- (a) ΔPQR is equilateral.
- (b) ΔPQR is acute angled.
- (c) Both [a] and [b]
- (d) Neither [a] nor [b]

Question 7. Which vertex of ΔABC is right angled if $\overline{AB} = 8$ cm, $\overline{AC} = 6$ cm, and $\overline{BC} = 10$ cm,?

- (a) $\angle C$
- (b) $\angle A$
- (c) $\angle B$
- (d) A or C

Question 8. An isosceles triangle is constructed as shown in the figure.

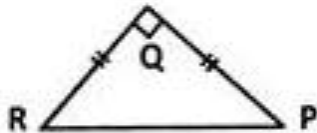

Which of the given statements is incorrect?

- (a) \overline{PR} is the hypotenuse of ΔPQR .
- (b) ΔPQR is an equilateral triangle.
- (c) ΔPQR is a right angled triangle.
- (d) If right angled ΔPQR has its equal angles measuring 45° each.

Question 9. ΔPQR is constructed with all its angles measuring 60° each. Which of the following is correct?

- (a) ΔPQR is an equilateral triangle.
- (b) ΔPQR is isosceles triangle.
- (c) ΔPQR is a scalene triangle.
- (d) ΔPQR is a right angled triangle.

Question 10. How many perpendicular lines can be drawn to a line from a point not on it?

- (a) 1
- (b) 2
- (c) 0
- (d) Infinite

Question 11. Identify the false statement.

- (a) A triangle with three equal sides is called an equilateral triangle.
- (b) A triangle with a right angle is called a right angled triangle.
- (c) A triangle with two equal sides is called a scalene triangle.
- (d) A right angled triangle has two acute angles and a right angle.

Question 12. ΔPQR is constructed such that $PQ = 5$ cm, $PR = 5$ cm and $\angle RPQ = 50^\circ$
Identify the type of triangle constructed.

- (a) An isosceles triangle
- (b) An acute angled triangle
- (c) An obtuse angled triangle
- (d) Both [a] and [b]

Question 13. Which of the following is NOT constructed using a ruler and a set square?

- (a) A perpendicular to a line from a point not on it.
- (b) A perpendicular bisector of a line segment.
- (c) A perpendicular to a line at a point on the line.
- (d) A line parallel to a given line through a given point.

Question 14. Study the steps of construction given.

Step 1: Draw a ray OA.

Step 2: With O as center and any convenient radius draw an arc MN to cut OA at M.

Step 3: With M as center and the same radius draw an arc to cut MN at P.

Step 4: With P as center and the same radius, draw an arc to cut MN at Q.

Step 5: Draw OQ and produce it to D. An angle AOD is constructed.

What is the measure of $\angle AOD$?

- (a) 60°
- (b) 30°
- (c) 120°
- (d) 45°

Question 15. In ΔXYZ , x, y and z denote the three sides. Which of the following is incorrect?

- (a) $x - y > z$
- (b) $x + z > y$
- (c) $x - y < z$
- (d) $x + y > z$

Very Short Questions:

- State whether the triangle is possible to construct if
 - In $\triangle ABC$, $m\angle A = 80^\circ$, $m\angle B = 60^\circ$, $AB = 5.5$ cm
 - In $\triangle PQR$, $PQ = 5$ cm, $QR = 3$ cm, $PR = 8.8$ cm
- Draw an equilateral triangle whose each side is 4.5 cm.

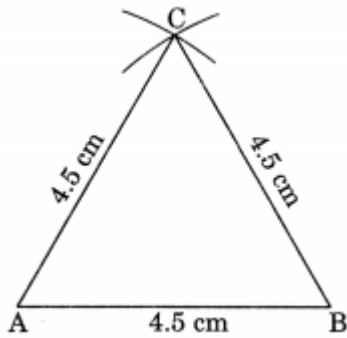

- Draw a $\triangle PQR$, in which $QR = 3.5$ cm, $m\angle Q = 40^\circ$, $m\angle R = 60^\circ$.

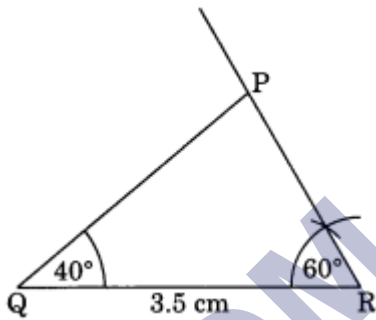

- There are four options, out of which one is correct. Choose the correct one:
 - A triangle can be constructed with the given measurement.
 - 1.5 cm, 3.5 cm, 4.5 cm
 - 6.5 cm, 7.5 cm, 15 cm
 - 3.2 cm, 2.3 cm, 5.5 cm
 - 2 cm, 3 cm, 6 cm
 - $m\angle P = 40^\circ$, $m\angle Q = 60^\circ$, $AQ = 4$ cm
 - $m\angle B = 90^\circ$, $m\angle C = 120^\circ$, $AC = 6.5$ cm
 - $m\angle L = 150^\circ$, $m\angle N = 70^\circ$, $MN = 3.5$ cm
 - $m\angle P = 105^\circ$, $m\angle Q = 80^\circ$, $PQ = 3$ cm
- What will be the other angles of a right-angled isosceles triangle?

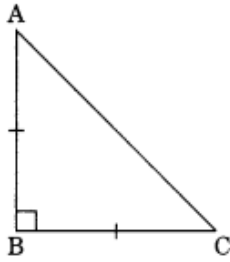

Short Questions:

1. What is the measure of an exterior angle of an equilateral triangle?

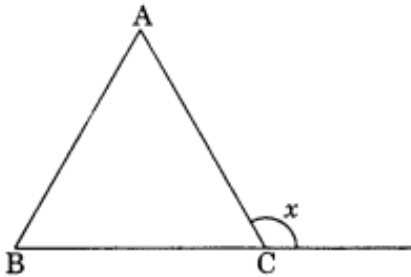

2. In $\triangle ABC$, $\angle A = \angle B = 50^\circ$. Name the pair of sides which are equal.

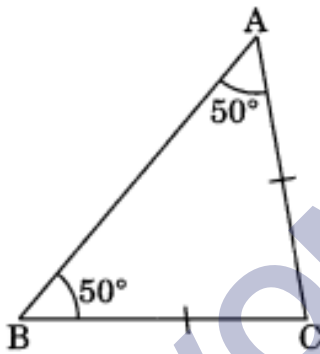

3. If one of the other angles of a right-angled triangle is obtuse, whether the triangle is possible to construct.
4. State whether the given pair of triangles are congruent.

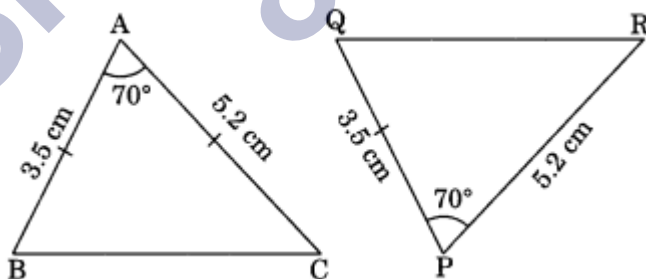

5. Draw a $\triangle ABC$ in which $BC = 5$ cm, $AB = 4$ cm and $m \angle B = 50^\circ$.

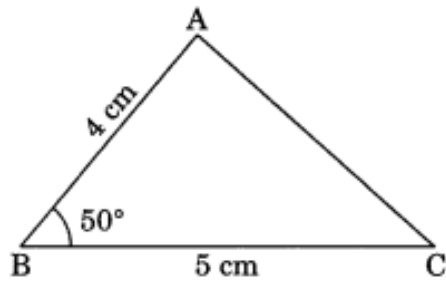

Long Questions:

1. Draw ΔPQR in which $QR = 5.4$ cm, $\angle Q = 40^\circ$ and $PR = 6.2$ cm.

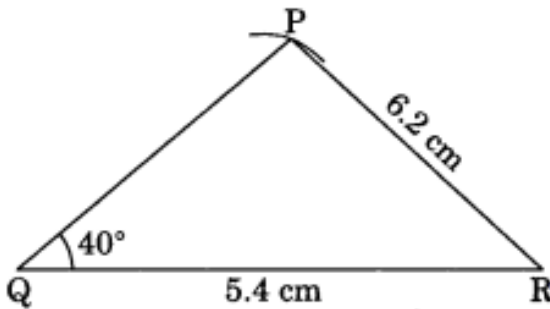

2. Construct a ΔPQR in which $m\angle P = 60^\circ$ and $m\angle Q = 30^\circ$, $QR = 4.8$ cm.

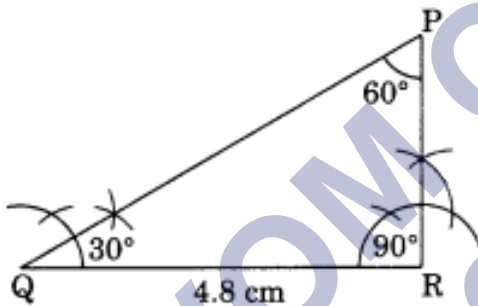

3. Draw an isosceles right-angled triangle whose hypotenuse is 5.8 cm.
4. Construct a ΔABC such that $AB = 6.5$ cm, $AC = 5$ cm and the altitude AP to BC is 4 cm.

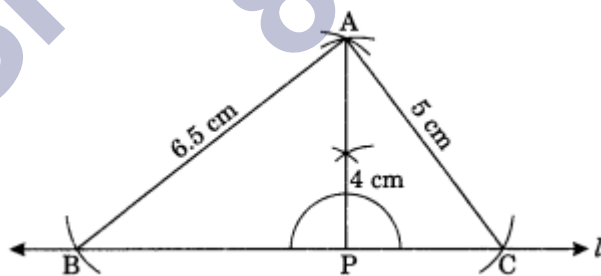

5. Construct an equilateral triangle whose altitude is 4.5 cm.

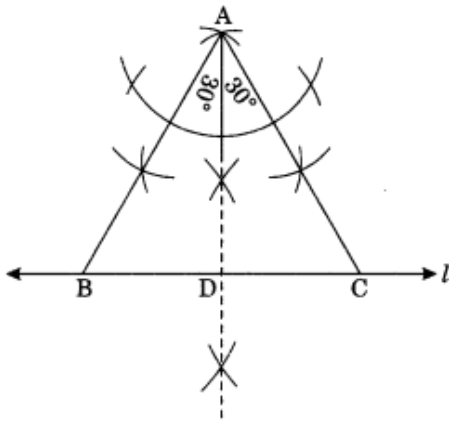

Answer Key-

Multiple Choice questions-

1. (a) A.S.A. criterion
2. (d) S.S.S. criterion
3. (a) A line parallel to a given line.
4. (c) The vertex B cannot be uniquely located.
5. (a) Equal corresponding angles.
6. (c) Both [a] and [b]
7. (b) $\angle A$
8. (b) ΔPQR is an equilateral triangle.
9. (a) ΔPQR is an equilateral triangle.
10. (a) 1
11. (c) A triangle with two equal sides is called a scalene triangle.
12. (d) Both [a] and [b]
13. (b) A perpendicular bisector of a line segment.
14. (c) 120°
15. (a) $x - y > z$

Very Short Answer:

1. (a) $m\angle A = 80^\circ$, $m\angle B = 60^\circ$
 $m\angle A + m\angle B = 80^\circ + 60^\circ = 140^\circ < 180^\circ$
 So, ΔABC can be possible to construct.
 (b) $PQ = 5$ cm, $QR = 3$ cm, $PR = 8.8$ cm

$$PQ + QR = 5 \text{ cm} + 3 \text{ cm} = 8 \text{ cm} < 8.8 \text{ cm}$$

$$\text{or } PQ + QR < PR$$

So, the ΔPQR can not be constructed.

2. Steps of construction:

(i) Draw $AB = 4.5 \text{ cm}$.

(ii) Draw two arcs with centres A and B and same radius of 4.5 cm to meet each other at C.

(iii) Join CA and CB.

(iv) ΔCAB is the required triangle.

3. Steps of construction:

(i) Draw $QR = 3.5 \text{ cm}$.

(ii) Draw $\angle Q = 40^\circ$, $\angle R = 60^\circ$ which meet each other at P.

(iii) ΔPQR is the required triangle

4. (i) Option (a) is possible to construct.

$$1.5 \text{ cm} + 3.5 \text{ cm} > 4.5 \text{ cm}$$

(ii) Option (a) is correct.

$$m\angle P + m\angle Q = 40^\circ + 60^\circ = 100^\circ < 180^\circ$$

5. In right angled isosceles triangle ABC, $\angle B = 90^\circ$

$$\angle A + \angle C = 180^\circ - 90^\circ = 90^\circ$$

But $\angle A = \angle C$

$$\angle A = \angle C = \frac{90}{2} = 45^\circ$$

Hence the required angles are $\angle A = \angle C = 45^\circ$

Short Answer:

1. We know that the measure of each interior angle = 60°

$$\text{Exterior angle} = 180^\circ - 60^\circ = 120^\circ$$

2. $\angle A = \angle B = 50^\circ$

$AC = BC$ [\because Sides opposite to equal angles are equal]

Hence, the required sides are AC and BC.

3. We know that the angles other than right angle of a right-angled triangle are acute angles.

So, such a triangle is not possible to construct.

Here, $AB = PQ = 3.5 \text{ cm}$

$$AC = PR = 5.2 \text{ cm}$$

$$\angle BAC = \angle QPR = 70^\circ$$

$$\triangle ABC = \triangle PQR \text{ [By SAS rule]}$$

4. Steps of construction:

(i) Draw $BC = 5 \text{ cm}$.

(ii) Draw $\angle B = 50^\circ$ and cut $AB = 4 \text{ cm}$.

(iii) Join AC .

(iv) $\triangle ABC$ is the required triangle.

5. Steps of construction:

(i) Draw $QR = 5.4 \text{ cm}$.

(ii) Draw $\angle Q = 40^\circ$.

(iii) Take R as the centre and with radius 6.2 cm , draw an arc to meet the former angle line at P .

(iv) Join PR .

(v) $\triangle PQR$ is the required triangle.

Long Answer:

1. $m\angle Q = 30^\circ$, $m\angle P = 60^\circ$

$$m\angle Q + m\angle P + m\angle R = 180^\circ \text{ (Angle sum property of triangle)}$$

$$30^\circ + 60^\circ + m\angle R = 180^\circ$$

$$90^\circ + m\angle R = 180^\circ$$

$$m\angle R = 180^\circ - 90^\circ$$

$$m\angle R = 90^\circ$$

2. Steps of construction:

(i) Draw $QR = 4.8 \text{ cm}$.

(ii) Draw $\angle Q = 30^\circ$.

(iii) Draw $\angle R = 90^\circ$ which meets the former angle line at P .

$$(iv) \angle P = 180^\circ - (30^\circ + 90^\circ) = 60^\circ$$

(v) $\triangle PQR$ is the required triangle.

3. Right angled triangle is an isosceles triangle

$$\text{Each of its acute angles} = \frac{90}{2} = 45^\circ$$

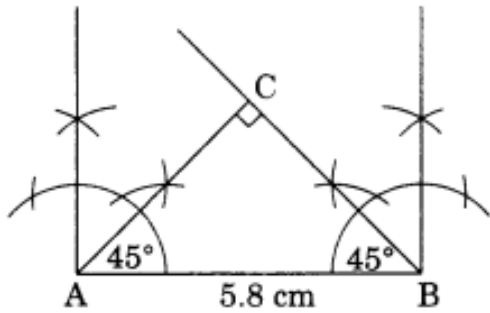

Steps of construction:

- (i) Draw $AB = 5.8$ cm.
- (ii) Construct $\angle A = 45^\circ$ and $\angle B = 45^\circ$ to meet each other at C.
- (iii) $\angle C = 180^\circ - (45^\circ + 45^\circ) = 90^\circ$
- (iv) $\triangle ACB$ is the required isosceles right angle triangle.

4. Steps of construction:

- (i) Draw a line l and take any point P on it.
- (ii) Construct a perpendicular to l at P .
- (iii) Cut $AP = 4$ cm.
- (iv) Draw two arcs with centre A and radii 6.5 cm and 5 cm to cut the line l at B and C respectively.
- (v) Join AB and AC .
- (vi) $\triangle ABC$ is the required triangle.

5. Steps of construction:

- (i) Draw any line l and take a point D on it.
- (ii) Construct a perpendicular to l at D and cut $AD = 4.5$ cm.
- (iii) Draw the angle of 30° at on either side of AD to meet the line l at B and C .
- (iv) $\triangle ABC$ is the required equilateral triangle.